

## Research Article

# Biochemical and Mechanical Characterization of Enzyme-Digestible Hydrogels

Waleed S. W. Shalaby<sup>1</sup> and Kinam Park<sup>1,2</sup>

Received November 8, 1989; accepted February 10, 1990

Albumin-cross-linked hydrogels were prepared by free radical polymerization using 1-vinyl-2-pyrrolidinone as a monomer and functionalized albumin as a crosslinking agent. The degree of chemical cross-linking was controlled by varying the degree of albumin functionality and the concentration of albumin. With emphasis placed on the potential use of these hydrogels for long-term oral drug delivery, gel characterization studies examined both the swelling and the mechanical properties in the absence and presence of pepsin. In the absence of pepsin, the equilibrium swelling ratio in simulated gastric fluid ranged from 17 to 55, depending on the degree of albumin functionality and the albumin concentration. Swelling was pH dependent at pH's greater than 7. The uptake of solvent into the dried hydrogels was determined to be Fickian. The integrity of swelling gels was dependent on the concentration of the functionalized albumin as well as on the degree of albumin functionality. In the presence of pepsin, a predominance of either surface or bulk degradation was observed, depending on the functionality of the albumin used as a cross-linker. Gel integrity during pepsin degradation also showed a marked dependence on the albumin functionality.

**KEY WORDS:** hydrogel; swelling ratio; albumin; pepsin; drug delivery; gel integrity.

## INTRODUCTION

The relatively brief gastrointestinal transit times of digestible materials have substantially hindered the development of once-a-day oral drug delivery systems (1). The use of bioadhesives, floating systems, and size exclusion devices has shown little success in achieving gastrointestinal residence times near the 24-hr time range (2-9). The transit time for digestible or nondigestible materials from mouth to cecum varies from 3 to 12 hr, and it is thought that this variability is due to variable gastric emptying (10,11). During the fed state of digestion, particles with diameters between 2.0 and 13 mm are likely to be repelled because of antropyloric closure in response to peristaltic contractions; however, while in the fasting state, these particles will be emptied because of the migrating motor complex (housekeeper wave) which occurs every 2 hr (12,13). Therefore, a drug delivery system with selective retention in the stomach following the migrating motor complex holds promise for achieving 24-hr drug delivery. Such a system should undergo large swelling to simplify swallowing and prevent duodenal entrance, with sufficient integrity to overcome gastric contractions, and biodegradability to simplify removal. Highly swellable biodegradable hydrogels may elicit these properties. We recently prepared albumin-cross-linked hydrogels as models (14). For oral drug delivery, it is important to develop *in vitro* tests to predict hydrogel responses in an

*vivo* situation. Here, we characterize the swelling and the mechanical and degradative properties of enzyme-digestible albumin-cross-linked hydrogels for once-a-day drug delivery.

## MATERIALS AND METHODS

### Alkylation of Albumin

Human serum albumin (Sigma, Fraction V) was alkylated using glycidyl acrylate (Aldrich) as described previously (14). Alkylation of other proteins was reported by other investigators (15,16). The extent of alkylation was measured using a method described by Snyder and Sobocinski (17). In our study, the alkylation reaction was carried out for 0.5, 1, 2, 5, 12, 19, 26, and 49 hr prior to termination with glycine. The purity of the functionalized albumin (FA) samples was tested using a UV spectrophotometer. Absorbance values were measured at a wavelength of 253.5 nm to determine the presence of glycidyl acrylate. The detection limit for this test was 3.9 µg/ml.

### Synthesis of Albumin-Cross-Linked Hydrogels

1-Vinyl-2-pyrrolidinone (VP; Aldrich) was polymerized in distilled deionized water at 40% (w/v) in the presence of FA. The concentrations of FA used were 4.5% (w/w), 6.0% (w/w), and 8.0% (w/w) of the monomer. Additional gels were prepared using the above crosslinking concentrations but with varied degrees of albumin functionality. The degree of functionality is henceforth referred to as the degree of albu-

<sup>1</sup> Purdue University, School of Pharmacy, West Lafayette, Indiana 47907.

<sup>2</sup> To whom correspondence should be addressed.

min alkylation. The monomeric solution was prepared by first solubilizing the initiator 2,2-azobis[2-methyl-propionitrile] (ABMP; Eastman Kodak) in previously degassed VP followed by the addition of FA, the cross-linking agent. The initiator concentration in all reactions was 1.0% (w/w) of the monomer. The solution was then transferred to a 5-ml plastic syringe and allowed to react for 12 hr at 60°C. The polyvinylpyrrolidone (PVP) hydrogels were cut into disks and washed in distilled deionized water. The water was changed 10 times over a 3-day period. Absorbance at 266 nm was used to determine the residual monomer content in the gel-equilibrated water. The detection limit for this test was 1.95 µg/ml.

### Equilibrium Swelling Studies

Synthesized hydrogels were cut in the fully swollen state by a cylindrical die having a diameter of 1 cm. Gels were categorized by the percentage of FA used as the cross-linker and by the degree of albumin alkylation. The gels were air-dried for 24 hr, followed by oven drying at 60°C for 12 hr. Three dried gels for each percentage of FA and degree of albumin alkylation were then weighed and later placed in the pepsin-free simulated gastric fluid (18) for 32 hr at 37°C. The time required for these systems to reach equilibrium was predetermined by monitoring the change in diameter of initially dried gel discs in similar conditions. The swelling ratio ( $Q$ ) was determined from the following relationship:

$$Q = W^*/W$$

where  $W^*$  and  $W$  are the weights of the swollen and dry gels, respectively.

### Dynamic Swelling Studies

Gels containing 8% of the FA were cut and dried as previously mentioned. Four dried gels were weighed and then placed in pepsin-free simulated gastric fluid. At timed intervals, the swelling gels were removed, weighed, and returned to their original solution. This procedure was carried out for 32 hr.

### pH-Dependent Swelling

To test for fluctuations in swelling which may result from pH changes, gels containing 8 and 4.5% of the FA having a degree of albumin alkylation of either 15 or 90% were cut and dried. Once weighed, the gels were equilibrated in 0.1 M buffer solutions at 37°C. The pH of buffers ranged from 1 to 9. The equilibrium swelling ratio ( $Q_{eq}$ ) was calculated and a possible relationship between  $Q_{eq}$  and pH was examined.

### Gel Integrity Studies

To examine the resiliency that the swollen hydrogels may possess when exposed to stresses induced by gastric contractions, a simple compression apparatus was developed using a 50-ml glass syringe (Fig. 1). Our apparatus is similar to the one developed by the food industry for the characterization of pectin gels (19). The strength that gels

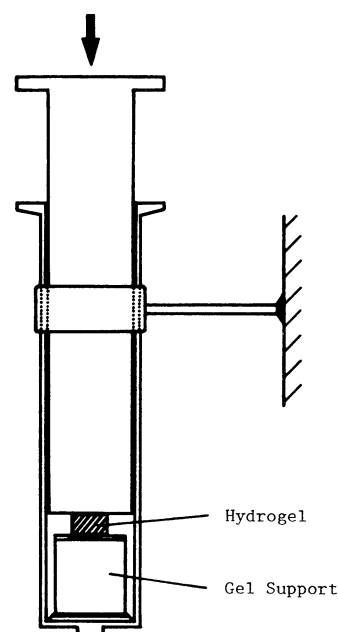

Fig. 1. Hydrogel compression apparatus for the measurement of ultimate compressive strengths.

could withstand prior to disruption is called the “ultimate compressive strength (UCS).”

To examine the relationship between the UCS and the degree of albumin alkylation, four disks with a diameter of 5 mm and a thickness of 3 mm were cut from each gel sample in the swollen state and equilibrated in a 0.1 M HCl solution at 37°C. The study was carried out by removing one gel as a test sample from a particular set of gels and placing it on the center of the gel support in Fig. 1. The plunger plus an empty plastic container was applied to compress the gel. The load was applied for 15 sec and then removed. Twenty milliliters of water was then added to the plastic container and the new load was applied for 15 sec and removed. If gel disruption did not occur, additional amounts of water (20 ml) were incrementally added to the container and applied for 15 sec. The amount of water was increased until the test sample ruptured. For the remaining gels of a particular set, 80% of the maximum load obtained from the test sample experiment was used as the starting load for compression studies. The UCS was determined by calculating the force required to rupture the gel per unit area of the plunger in contact with the gel. The force exerted on the gel was the sum of the following forces:

$$F(\text{exerted}) = F(\text{plunger}) + F(\text{container}) + F(\text{water}) - F(\text{friction})$$

From the above equation, the negative force which arises as a result of the kinetic friction between the plunger and the syringe barrel was determined by inverting the plunger-containing syringe on one plate of a torsion balance while allowing only the end of the plunger to be in contact with the plate. The minimum amount of force applied to the adjoining plate of the balance which resulted in the continual upward movement of the plunger within the syringe barrel was approximated to be the minimum force required to overcome

the opposing force because of the kinetic friction. The frictional force was found to be less than 3% of the actual force from the plunger alone.

### Enzyme Digestion of Functionalized Albumin

Electrophoresis samples were first prepared by reacting pepsin in simulated gastric fluid with both regular albumin and the FA having a degree of alkylation of 90%. The concentration of pepsin (Sigma, 2500 units/mg) in the reaction mixture was 83 units/ml. The reactions were carried out for periods of 15, 30, 60, and 120 min before termination with the denaturant [20% glycerol, 0.2% sodium dodecyl sulfate (SDS), 0.25 M Tris, 0.25% mercaptoethanol, pH 6.8]. The reduction of the protein was carried out at 37°C for 48 hr. Electrophoresis was performed according to the method of Laemmli (20). Gel staining was achieved using Coomassie brilliant blue R-250 (Bio-Rad).

### Swelling of Dried Hydrogels in the Presence of Pepsin

To characterize the degradable properties of these systems, four dried gels from each sample were exposed to pepsin-containing simulated gastric fluid at 37°C. During the uptake of penetrants, the weight of swollen gels was recorded over time until pepsin digestion rendered them unsuitable for continued measurements. The swelling ratio ( $Q$ ) was calculated and compared with the swelling behavior of these gels over time in the absence of pepsin. In all gel digestion studies, the pepsin concentration was held constant at 250 units/ml. From previous work in our laboratory, pepsin concentrations in simulated gastric fluid exceeding 125 units/ml had little or no additional effect on the degradation of similar albumin-cross-linked hydrogels (21).

### UCS Studies During Pepsin Digestion of Dynamically Swelling Hydrogels

Four gels from each sample containing 8% FA were cut and dried as mentioned above. The degree of albumin alkylation was varied at 27, 50, and 90%. The gels were then placed in pepsin-containing simulated gastric fluid at 37°C. Samples were removed at specific time intervals and tested for the UCS. The test procedure followed was discussed in the earlier UCS experiment; however, with respect to the initial test sample, 100-ml, instead of 20-ml, increments of water were added. This was designed to shorten the time required to determine the UCS.

## RESULTS

### Swelling Characterization Studies

By using FA as a multifunctional cross-linker, one can produce hydrogels with a variety of swelling, degradation, and mechanical properties. Since albumin could be alkylated to as much as 90% and as little as 7.9% of the total available sites, one can effectively increase the degree of chemical crosslinking in the network while maintaining the same concentration of FA. The extent to which the alkylation reaction between glycidyl acrylate and albumin could be carried out is shown in Fig. 2. The degree of albumin alkylation was easily varied by controlling the reaction time. Figure 3 shows

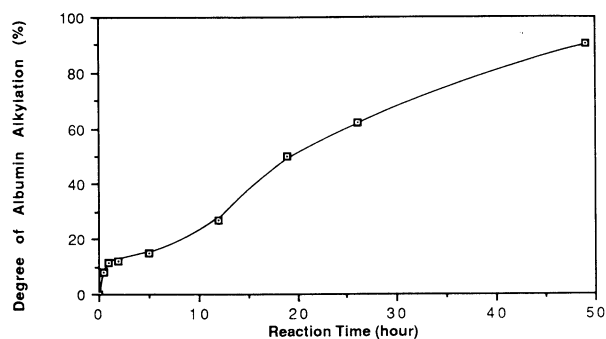

Fig. 2. Degree of albumin alkylation as a function of reaction time. Glycidyl acrylate (200  $\mu$ l) was added to 5 ml of a 5% albumin solution while stirring at room temperature.

the equilibrium swelling ratios ( $Q_{eq}$ ) of hydrogels which were prepared with various FA cross-linkers. As the degree of albumin alkylation increased up to 27%,  $Q_{eq}$  decreased almost linearly. Small differences in  $Q_{eq}$ , however, were observed when the degree of albumin alkylation was above 27%. The plateau effect observed at high degrees of albumin alkylation is useful in controlling the rigidity of hydrogels while maintaining the same  $Q_{eq}$  (see below).

Since PVP is a water-soluble polymer, the albumin-cross-linked PVP hydrogels prepared were expected to possess desirable swelling properties. The  $Q_{eq}$  ranged from 17 to 55 depending on the concentration of FA and the degree of albumin alkylation. The water contents for the above range of  $Q_{eq}$  values were between 94 and 98%. From the dynamic swelling experiments in pepsin-free simulated gastric fluid, it was found that 60% of the equilibrium swelling could be attained within the first 3 hr of exposure for all the hydrogels used in our study (Fig. 4). The uptake of the first 60% of penetrant was directly proportional to the square root of time, with a correlation coefficient of 0.999 (Fig. 5).

Albumin, like all other proteins, possesses an isoelectric point ( $pI$ ). Consequently, a net negative or positive charge is produced with changes in pH around the  $pI$ . Since PVP was cross-linked with FA, it was thought that swelling fluctuations might be induced as a function of pH around the  $pI$  of albumin, which is known to be 4.8 (22). With respect to the gastrointestinal tract, it has been reported that the antral pH

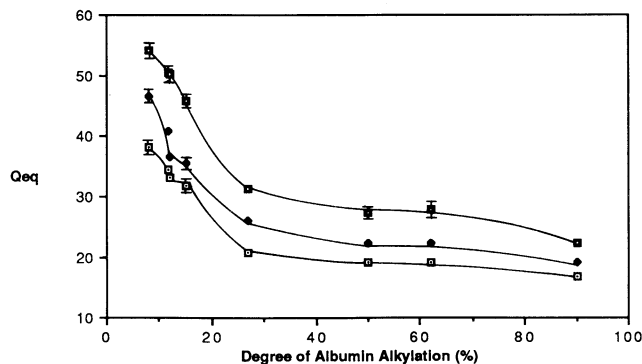

Fig. 3. Equilibrium swelling ratio ( $Q_{eq}$ ) as a function of the degree of albumin alkylation. The concentration of FA was 4.5% ( $\square$ ), 6% ( $\blacklozenge$ ), and 8% ( $\square$ ). The absence of an error bar indicates that the standard deviation of the data was smaller than the size of the symbol ( $n = 3$ ).

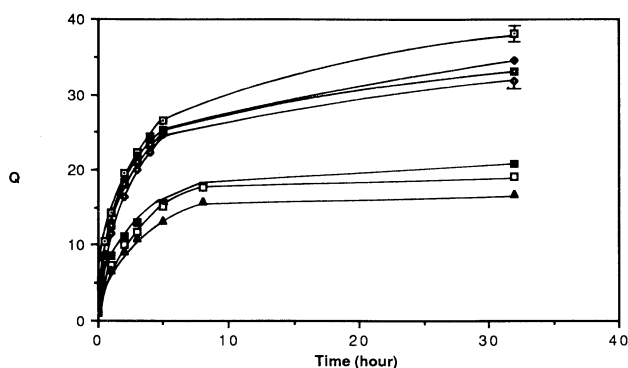

Fig. 4. Dynamic swelling of albumin-cross-linked hydrogels containing 8% FA as a function of time. The degree of albumin alkylation was 7.9% ( $\square$ ), 11.7% ( $\blacklozenge$ ), 12% ( $\square$ ), 15% ( $\diamond$ ), 27% ( $\blacksquare$ ), 50% ( $\square$ ), and 90% ( $\blacktriangle$ ). The absence of an error bar indicates that the standard deviation of the data was smaller than the size of the symbol ( $n = 4$ ).

can reach levels as high as pH 7 during phase III activity in humans (23). From Fig. 6, a marked increase in  $Q$  was observed at pH >7. It was suggested that enolization of PVP at the carbonyl may produce a net negative charge; however, this was reported at pH >12 (24) and is believed to be minimal, if not completely absent, in our studies. Thus, our data suggest that the increase in  $Q$  may be attributed to the net negative charge on the albumin cross-linker which establishes an osmotic pressure gradient to promote additional swelling. The magnitude of this increase appears to be related to the degree of chemical cross-linking, which is proportional to the degree of albumin alkylation and concentration of FA. The increased values for  $Q$  are, however, only partially reversible when gels preequilibrated in a pH 9 buffer were later equilibrated in a pH 4 buffer. This observation suggests that conformational changes with the FA can occur as a function of pH but with only partial reversibility. No substantial increase in swelling was observed at pH <4.8. To explain accurately the pH-dependent swelling behavior, further studies are required.

**Gel Integrity Studies**

From the UCS studies it was found that the number of chemical cross-links coupled with polymeric chain mobility can account for the individual gel responses to compression.

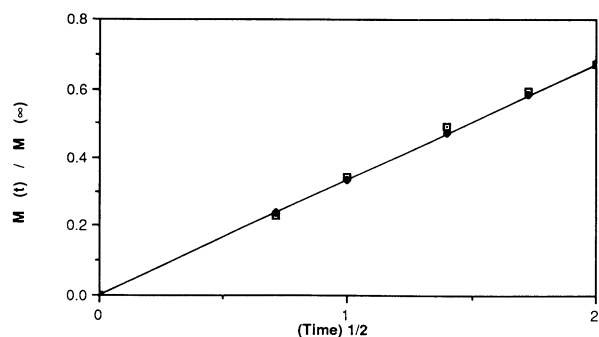

Fig. 5. Penetrant uptake as a function of the square root of time for albumin-cross-linked hydrogels containing 8% FA with a degree of albumin alkylation of 15%. Experimental ( $\square$ ) and theoretical ( $\blacklozenge$ ).

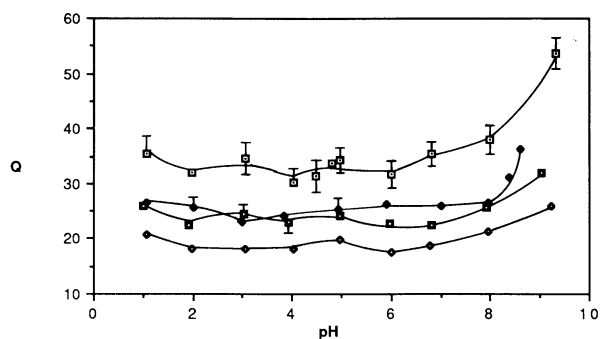

Fig. 6. Equilibrium swelling ratio of albumin-cross-linked hydrogels as a function of pH.  $\square$ , 4.5% FA [degree of albumin alkylation (DAA), 15%];  $\blacklozenge$ , 4.5% FA (DAA, 90%);  $\square$ , 8% FA (DAA, 15%);  $\diamond$ , 8% FA (DAA, 90%). The absence of an error bar indicates that the standard deviation of the data was smaller than the size of the symbol ( $n = 4$ ).

Figure 7 shows the relationship between the UCS and the degree of albumin alkylation. The maximum UCS at a given albumin concentration arises at intermediate values of albumin alkylation. This illustrates that gels having polymeric chains, which are more restricted because of increased chemical cross-links, will tend to disrupt more readily in response to a compression load than those with more mobile chains. It appears that an optimum number of chemical cross-links must be present in order to elicit ideal gel compressibility. The optimized local chain mobility and restricted gross mobility are general properties common to elastomers (25). As the concentration of FA increased, the maximum UCS occurred with gels that had lower degrees of albumin alkylation (Fig. 8). For gels containing 8% FA, the maximum UCS occurred at a degree of albumin alkylation of 27%, whereas the maximum UCS for gels containing 6% FA occurred at a degree of albumin alkylation of 50%. This result tends to support further the concept of an ideal degree of chemical crosslinking.

**Enzyme Digestion Studies**

The alkylation of albumin by glycidyl acrylate provided a means to control the digestibility of albumin-cross-linked

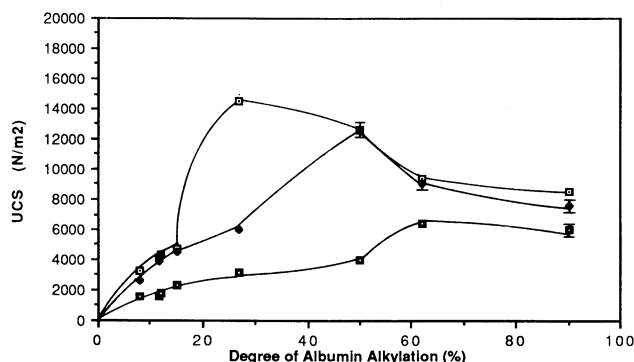

Fig. 7. Ultimate compressive strength as a function of the degree of albumin alkylation. The concentration of FA was 4.5% ( $\square$ ), 6% ( $\blacklozenge$ ), and 8% ( $\square$ ). The absence of an error bar indicates that the standard deviation of the data was smaller than the size of the symbol ( $n = 4$ ).

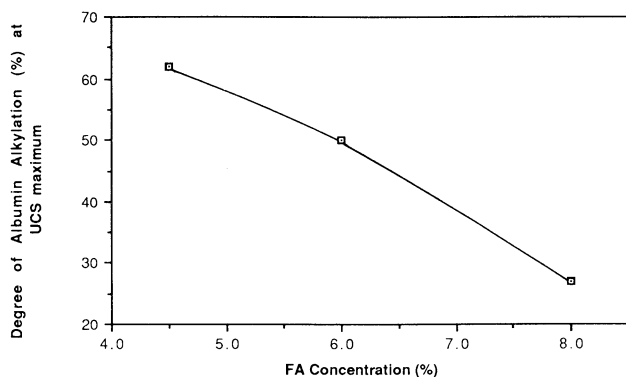

Fig. 8. Degree of albumin alkylation at the maximum UCS as a function of FA concentration.

hydrogels by pepsin. The varied resistance to enzymatic degradation was related to the degree of albumin alkylation.

It was observed from gel electrophoresis studies that fragment sizes of the FA samples over specific digestion times were larger than those of the control albumin samples (Fig. 9). The larger fragments associated with FA may indicate that a smaller number of available sites exist on FA for cleavage by pepsin. Consequently, alkylation of albumin is believed to retard degradation of albumin by pepsin. From Fig. 9, one will also observe diffused protein bands for the FA samples. The diffused band is usually due to the formation of multimers (26). Thus, the diffused band in Fig. 9 is believed to be due to the formation of intermolecular cross-links resulting from the reactable moieties of the FA. It is not yet clear, however, how and when the cross-linking had occurred among the functionalized albumin molecules.

With respect to the degradable properties of the albumin-cross-linked hydrogels, we considered those gels containing various concentrations of FA with degrees of albumin alkylation ranging from 7.9 to 15%. In the presence of pepsin, the swelling profiles were dependent on the degree of albumin alkylation (Fig. 10A). For gels having a FA concentration of 8% and a degree of albumin alkylation of 15%, the

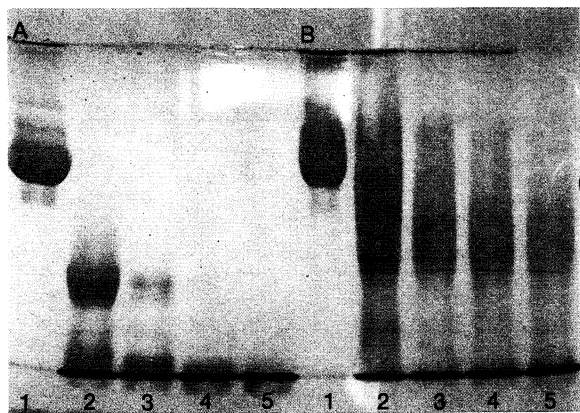

Fig. 9. Gel electrophoresis of control albumin (A) and functionalized albumin (B). Column 1 represents the pepsin-free samples. Columns 2–5 represent enzymatic digestion of either control albumin or FA at specified times prior to termination with denaturant. Albumin was digested by pepsin (83 units/ml) for 15 min (column 2), 30 min (column 3), 60 min (column 4), and 120 min (column 5).

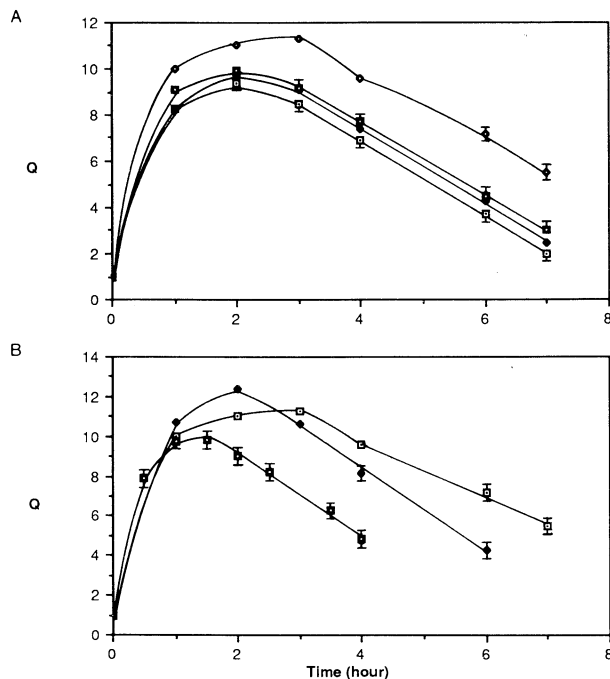

Fig. 10. (A) Dynamic swelling as a function of time in the presence of pepsin for gels containing 8% FA. The degree of albumin alkylation was 7.9% ( $\square$ ), 11.7% ( $\blacklozenge$ ), 12% ( $\blacksquare$ ), and 15% ( $\blacklozenge$ ). (B) Dynamic swelling as a function of time in the presence of pepsin. The degree of albumin alkylation was 15% and the concentration of FA was 4.5% FA ( $\square$ ), 6% ( $\blacklozenge$ ), and 8% ( $\square$ ). The absence of an error bar indicates that the standard deviation of the data was smaller than the size of the symbol ( $n = 4$ ).

maximum swelling ratio ( $Q_{\max}$ ) occurred at 3 hr, while gels containing a FA concentration of 8% and a degree of albumin alkylation of 7.9% showed  $Q_{\max}$  after 2 hr. The  $Q_{\max}$  occurred at later times as the degree of albumin alkylation was increased. As the concentration of FA was reduced,  $Q_{\max}$  occurred at earlier times (Fig. 10B). For gels having a 15% degree of albumin alkylation,  $Q_{\max}$  for an 8% FA concentration occurred at 3 hr. When the FA concentration was reduced to 6 and 4.5%,  $Q_{\max}$  occurred at 2 and 1.5 hr, respectively. By comparing these findings with the dynamic swelling of identical systems in pepsin-free simulated gastric fluid (Fig. 11), a sharp contrast in swelling profiles can be observed. At times exceeding 1 hr, the swelling ratio for gels swelling in the presence of pepsin becomes substantially lower than for gels swelling in the pepsin-free solution. This behavior is thought to be due to a predominance of the surface degradation over the bulk degradation. Since the swelling ratios of the degrading samples even in the early time period did not exceed those of the pepsin-free samples, minimum bulk degradation is supported. The existence of  $Q_{\max}$  may, in this case, represent the point at which the rate of gel swelling is equivalent to the rate of polymer loss at the gel surface. At times following the  $Q_{\max}$ , the rate of gel swelling will decrease while the rate of surface degradation remains relatively constant. The net effect observed was a reduction in  $Q$  to as low as 2, whereafter the gel was too small to be analyzed accurately. Furthermore, since the terminal slopes following  $Q_{\max}$  in Fig. 10A are close to linear, the net deg-

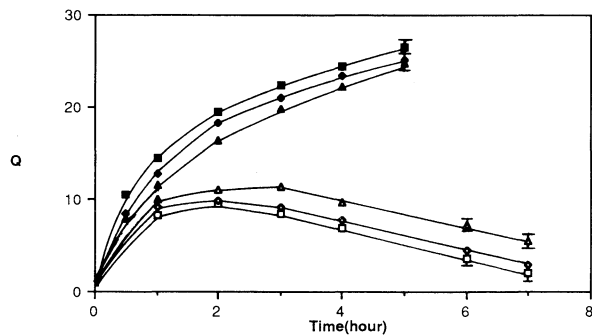

Fig. 11. Dynamic swelling of albumin-cross-linked hydrogels containing 8% FA as a function of time. The degree of albumin alkylation was 7.9% (□), 12% (◇), and 15% (△) in the presence of pepsin and 7.9% (■), 12% (◆), and 15% (▲) in the absence of pepsin. The absence of an error bar indicates that the standard deviation of the data was smaller than the size of the symbol ( $n = 4$ ).

radation process appears to be relatively constant thus partially supporting the arguments above.

In the case of albumin-cross-linked gels having a degree of albumin alkylation ranging from 27 to 90%, the effects of bulk degradation predominate in the early stages of swelling. In the presence of pepsin (Fig. 12A),  $Q_{max}$  was observed much later relative to samples studied with less than 27% of albumin alkylation. The time to reach  $Q_{max}$  decreased with decreasing concentrations of FA (Fig. 12B), while the time to reach  $Q_{max}$  increased with an increasing degree of albumin

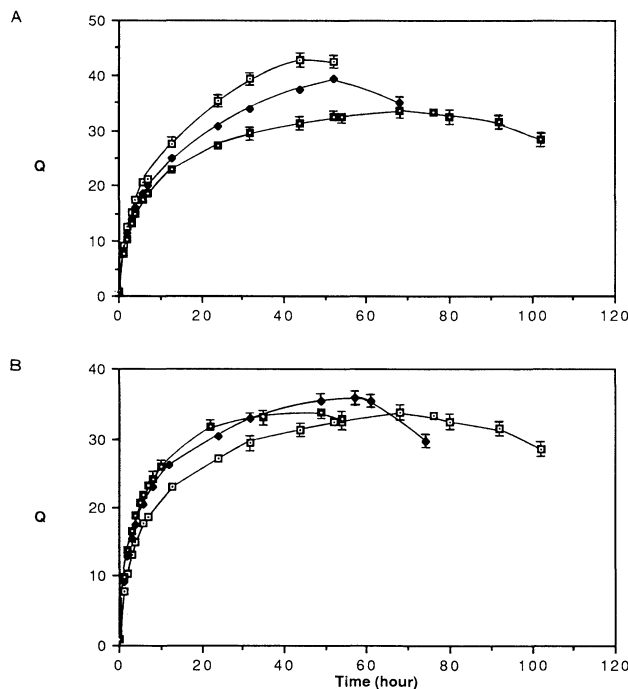

Fig. 12. (A) Dynamic swelling as a function of time in the presence of pepsin for gels containing 8% FA. The degree of albumin alkylation was 27% (□), 50% (◆), and 90% (■). (B) Dynamic swelling as a function of time in the presence of pepsin. The degree of albumin alkylation was 90% and the concentration of FA was 4.5% FA (□), 6% (◆), and 8% (◻). The absence of an error bar indicates that the standard deviation of the data was smaller than the size of the symbol ( $n = 4$ ).

alkylation. The  $Q_{max}$  for gels having an 8% FA concentration and a 90% degree of albumin alkylation occurred at 68 hr, whereas the  $Q_{max}$  for a degree of albumin alkylation of 50% occurred at 52 hr, and that for 27% at 44 hr. When the concentration of FA with a 90% degree of albumin alkylation was reduced to 6%, the  $Q_{max}$  occurred at 57 hr, and that for 4.5% at 49 hr (Fig. 12B). By comparing these results with the dynamic swelling profiles of identical gels in pepsin-free simulated gastric fluid (Fig. 13), it becomes apparent that bulk degradation is the primary mechanism of degradation. At times exceeding 8 hr, the swelling ratio for gels swelling in the presence of pepsin is distinctly greater than for those swelling under pepsin-free conditions. Swelling, in these cases, may be attributed to the net result of penetrant diffusion, bulk degradation, and surface degradation, with a greater emphasis placed on the bulk degradation prior to  $Q_{max}$ . Following the occurrence of  $Q_{max}$ , gels that contained 6 to 8% of FA tended to show decreases in  $Q$  until gel disruption occurred. Gel disruption was prolonged as the degree of albumin alkylation increased as well as with increases in the FA concentration. The important point here is that the predominance of either surface or bulk degradation can be controlled by the degree of albumin alkylation.

Based on the above enzyme digestion studies, the ultimate compressive strength of a selected group of gels was studied as a function of exposure time to pepsin in simulated gastric fluid (Fig. 14). Maximum gastric pressure in the fasted and fed state following a solid or a liquid meal was found by Houghton *et al.* to range from 80 to 100 mm Hg in humans (23,27). From this study, the magnitude of phasic contractions was approximated to range between 10,600 and 13,250 N/m<sup>2</sup>. This range is henceforth referred to as the "critical compressive strength range." The dotted lines in Fig. 14 show how the critical compressive strength range relates to the magnitude of the UCS from our studies. The purpose of this experiment was to determine if gels could withstand compression loads greater than or within the critical compressive strength range for extended periods of time. For this experiment, gels contained 8% of FA, while the degree of albumin alkylation ranged from 27 to 90%. Gels having a degree of albumin alkylation of 27 and 50% remained at or above the critical compressive strength range

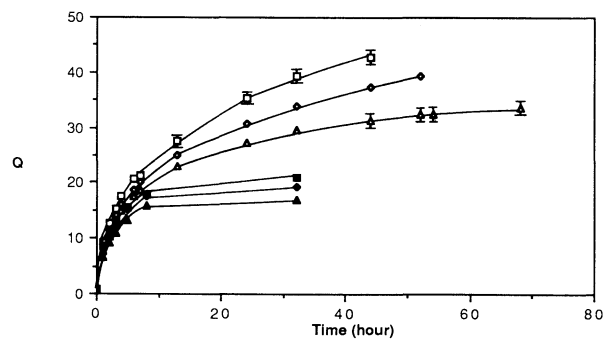

Fig. 13. Dynamic swelling of albumin-cross-linked hydrogels containing 8% FA as a function of time. The degree of albumin alkylation was 27% (□), 50% (◇), and 90% (△) in the presence of pepsin and 27% (■), 50% (◆), and 90% (▲) in the absence of pepsin. The absence of an error bar indicates that the standard deviation of the data was smaller than the size of the symbol ( $n = 4$ ).

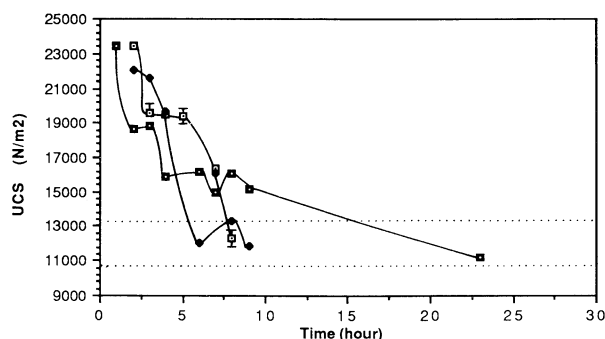

Fig. 14. Ultimate compressive strength as a function of time in the presence of pepsin for hydrogels containing 8% FA. The degree of albumin alkylation was 27% (□), 50% (◆), and 90% (□). The absence of an error bar indicates that the standard deviation of the data was smaller than the size of the symbol ( $n = 4$ ).

for 8 and 9 hr, respectively, following exposure to pepsin. Gels having a degree of albumin alkylation of 90% remained at or above the critical compressive strength range for 23 hr. This prolonged integrity in the presence of pepsin may be due to very slow digestion by pepsin. The fluctuations in UCS (Fig. 14) may be explained in part by the concept of the ideal degree of chemical cross-linking as discussed above.

## DISCUSSION

For the successful application of the enzyme-digestible swelling hydrogels for oral drug delivery with improved gastric retention, hydrogels must possess rapid swelling, structural rigidity, and optimum drug release properties. The focus of this work was to examine both the swelling and the structural aspects of the hydrogels. The swelling characterization studies showed that swelling was pH dependent at the basic pH range and could be controlled by the degree of albumin alkylation. From a dynamic standpoint, gels could swell to within 60% of their equilibrium swollen mass within 3 hr; moreover, in the presence of pepsin, gels which underwent net bulk degradation displayed more favorable swelling kinetics. Since very little is known about pepsin concentrations in the stomach during the fasted and fed states (28), the use of pepsin as a swelling enhancer may or may not be a practical approach. It, therefore, becomes apparent that the swelling kinetics of these systems need to be improved. In our laboratory, we are presently experimenting with albumin-cross-linked polyelectrolyte hydrogels to improve swelling properties.

The existence of two mechanisms of degradation which can be effectively controlled as a function of the degree of albumin alkylation is a unique phenomenon. We have seen that as the degree of albumin alkylation increases, albumin-cross-linked hydrogels become more impervious to surface degradation, the results of which are attributed largely to the slower digestion of albumin by pepsin as discussed above with the gel electrophoresis data. Since the degradability of the gel is dependent on the degree of albumin alkylation, a second factor must exist which controls the predominating mechanism of degradation. When a dried gel swells in the presence of pepsin, it is conceivable that two penetration fronts exist. The first is the pepsin-free front, and the second

the pepsin-containing front or the degrading front. The factor which determines the predominant mechanism of degradation is the FA's response to the degrading front. For gels which are cross-linked with rapidly digestible FA, that is, albumin with a low degree of alkylation, penetration by the degrading front will be limited to the gel surface, since the digestion of the FA and subsequent loss of polymer chains at the surface occur very efficiently. Thus, the actual size of the gel is reduced in a short period of time, while the bulk degradation appears to have a minimal effect. The net result will therefore be surface degradation. As the degree of albumin alkylation increases, FA is digested more slowly. As a result, the efficiency of the degrading front in digesting the FA is also reduced. Since the gel is now more impervious to degradation, the degrading front can penetrate into the gel, even though there may be some loss of polymer chains at the surface. With the net result being the penetration of the degrading front, bulk degradation becomes the predominant mechanism of degradation. With respect to gastric retention, it appears that the use of enzyme-digestible hydrogels that undergo a net surface degradation will be less than suitable because of their reduction in size over a short period of time; however, those gels that degrade by a net bulk degradation mechanism show promise.

In our understanding of gel integrity and how it may be studied in relation to the gastric environment, we had chosen compression as the single most important form of stress to mimic peristaltic contractions in the stomach. It may be argued, however, that the antral mixing and grinding process of solid foods in the fed state provides more of a shear than a compression stress. Nonetheless, for systems containing as much as 98% penetrant, compression was a more feasible and realistic method of analysis. From the literature, we had calculated a critical compressive strength range which was used to illustrate how *in vitro* compressive strengths may relate to actual *in vivo* stresses. Even though such extrapolation of the data may be premature without data from animal experiments, our technique can be used until a more accurate technique is found. Since phasic contractions in the stomach occur repeatedly, it is conceivable that our systems may lose integrity as a result of multiple contractions; furthermore, in the presence of other digestible material, gel integrity may also be reduced. With these possibilities in mind, future studies on gel integrity will focus on animal studies to establish a correlation between *in vitro* and *in vivo* tests.

The presence of pepsin will lead to drastic changes in the swelling behavior of gels. With respect to drug release, enzymatic degradation will be of significant importance. Enzymatic digestion will lead to gel swelling with the presence of either net bulk degradation or surface degradation. Altered drug release rates are likely to be observed because of changes in diffusion path length. Consequently, controlling the degradation kinetics becomes an important parameter to consider when developing biodegradable networks for oral drug delivery. This approach may be used as an effective tool to control the release of hydrophobic drugs or possibly hydrophilic drugs. For dissolved hydrophilic drugs, substantial release occurs before significant degradation. Thus, our future work will focus on controlling the rate of enzymatic degradation for the release of hydrophobic drugs or dis-

persed hydrophilic drugs. For once-a-day drug delivery systems, hydrogels may have to stay in the stomach for only 16 to 20 hr. This, however, can be determined only from animal experiments. Animal experiments can provide important information regarding degradation kinetics, pepsin concentrations, and contractile forces in the stomach. It is promising that albumin-cross-linked gels can be manipulated to undergo either net bulk or surface degradation while maintaining relatively good integrity for up to 24 hr.

In summary, the preliminary data collected in this study suggest that albumin-cross-linked hydrogels may, with additional modifications and tests, be used as a successful platform for once-a-day oral drug delivery.

#### ACKNOWLEDGMENT

This study was supported by the ICI Pharmaceuticals Group.

#### REFERENCES

1. A. F. Hoffman, J. H. Dressman, C. F. Code, and K. F. Witzun. Controlled entry of oral administered drugs: Physiological considerations. *Drug Dev. Ind. Pharm.* 9:1077-1109 (1983).
2. H. Bechgaard and K. Ladefoged. Distribution of pellets in the gastrointestinal tract. The influence on transit time exerted by the density or the diameter of pellets. *J. Pharm. Pharmacol.* 30:690-692 (1978).
3. S. S. Davis, J. G. Hardy, M. J. Taylor, D. R. Whalley, and C. G. Wilson. A comparative study of gastrointestinal transit of a pellet and tablet formulation. *Int. J. Pharm.* 21:167-177 (1984).
4. S. S. Davis, A. F. Stockwell, M. J. Taylor, J. G. Hardy, D. R. Whalley, C. G. Wilson, H. Bechgaard, and F. F. Christensen. The effect of density on the gastric emptying of single-multiple-unit dosage forms. *Pharm. Res.* 4:208-213 (1986).
5. S. S. Davis, F. N. Norring-Christensen, R. Khosla, and L. C. Feely. Gastric empty of large single unit dosage forms. *J. Pharm. Pharmacol.* 40:205-207 (1987).
6. P. Gruber, A. Rubinstein, V. H. K. Li, P. Bass, and J. R. Robinson. Gastric emptying of nondigestible solids in fasted dog. *J. Pharm. Sci.* 76:117-122 (1987).
7. H. M. Ingani, J. Timmermans, and A. J. Moes. Conception and in vivo investigation of peroral sustained release of floating dosage forms with enhanced gastrointestinal transit. *Int. J. Pharm.* 35:157-164 (1987).
8. H. S. Ch'ng, H. Park, P. Kelly, and J. R. Robinson. Bioadhesive polymers as platforms for oral controlled drug delivery. II. Synthesis and evaluation of some swelling, water-insoluble, bioadhesive polymers. *J. Pharm. Sci.* 74:399-405 (1985).
9. M. A. Longer, H. S. Ch'ng, and J. R. Robinson. Bioadhesive polymers as platforms for oral controlled delivery. III. Oral delivery of chlorothiazine using a bioadhesive polymer. *J. Pharm. Sci.* 74:406-411 (1985).
10. J. H. Bond and M. D. Levita. Investigations of small bowel transit time in man utilizing pulmonary hydrogen ( $H_2$ ) measurements. *J. Lab. Clin. Med.* 85:546-555 (1975).
11. P. L. Madan. Sustained release drug delivery systems. II. Preformulation considerations. *Pharm. Manufact.* 2:41-45 (1985).
12. H. Minami and R. W. McCallum. The physiology and pathophysiology of gastric emptying in humans. *Gastroenterology* 86:1592-1610 (1984).
13. H. M. Park, S. M. Chernish, B. D. Roseneik, R. L. Brunelle, B. Hargrove, and H. N. Wellman. *Digest. Dis. Sci.* 29:207-212 (1984).
14. K. Park. Enzyme-digestible swelling hydrogels as platforms for long-term oral drug delivery: Synthesis and characterization. *Biomaterials* 9:435-441 (1988).
15. D. Jaworek. New methods for covalent binding of proteins to synthetic polymers. In M. Salmons, C. Saronia, and S. Garattini (eds.), *Insoluble Enzymes*. Raven Press, New York, 1974, pp. 65-76.
16. V. P. Torchilin, A. V. Maksimenko, V. N. Smirnov, I. V. Berezin, A. M. Klibanov, and K. Martinek. The principles of enzyme stabilization. IV. Modification of functional groups in the tertiary structure of proteins. *Biochim. Biophys. Acta* 567:1-11 (1979).
17. S. L. Snyder and P. Z. Sobocinski. An improved 2,4,6-trinitrobenzenesulfonic acid method for the determination of amines. *Anal. Biochem.* 64:284-288 (1975).
18. United States Pharmacopeia/National Formulary. *USP XXI/NF XVI*, USP Convention Inc., 1985, p. 1424.
19. P. G. Crandall and L. Wicker. Pectin internal gel strength: theory, measurement, and methodology. Chemistry and functions of pectins. *ACS Symp. Ser.* 310:89-102 (1985).
20. U. K. Laemmli. Cleavage of structural proteins during the assembly of the head of bacteriophage T4. *Nature* 227:680 (1970).
21. C. K. Shim and K. Park. Examination of drug release from enzyme-digestible swelling hydrogels. *Proc. Int. Symp. Control. Rel. Bioact. Mater.* 16:219-220 (1989).
22. W. Norde, J. G. E. M. Fraaye, and J. Lyklema. Protein adsorption at Solid Liquid Interfaces: A colloid chemical approach. In J. L. Brash and T. A. Horbett (eds.), *Proteins at Interfaces*, Am. Chem. Soc., Washington, DC, 1987, pp. 36-47.
23. L. A. Houghton, N. W. Read, R. Heddle, G. J. Maddern, J. Downtown, J. Toouli, and J. Dent. Motor activity of the gastric antrum, pylorus, and duodenum under fasted conditions and after liquid meal. *Gastroenterology* 94:1276-1284 (1988).
24. G. O. Oster and E. H. Immergut. Ultraviolet and infrared spectral studies of polyvinylpyrrolidone. *J. Am. Chem. Soc.* 76:1393-1396 (1954).
25. F. W. Billmeyer Jr. *Textbook of Polymer Science*, Interscience, New York, 1962, pp. 180, 230-231.
26. K. Park, S. J. Gerndt, and H. Park. Patchwise adsorption of fibrinogen of glass surfaces and its implication in platelet adhesion. *J. Colloid Interf. Sci.* 125:702-711 (1988).
27. L. A. Houghton, N. W. Read, R. Heddle, M. Horowitz, P. J. Collins, B. Chatterton, and J. Dent. Relationship of the motor activity of the antrum, pylorus, and duodenum to gastric emptying of a solid-liquid mixed meal. *Gastroenterology* 94:1285-1291 (1988).
28. J. R. Malagelada, G. F. Longstreth, W. H. J. Summerskil, and V. L. W. Go. Measurements of gastric functions during digestion of ordinary solid meals in man. *Gastroenterology* 70:203-210 (1976).