

Modulated insulin delivery from glucose-sensitive hydrogel dosage forms

Jung Ju Kim, Kinam Park*

Departments of Pharmaceutics and Biomedical Engineering, School of Pharmacy, Purdue University, West Lafayette, IN 47907, USA

Received 6 March 2001; accepted 18 July 2001

Abstract

Glucose-sensitive hydrogels that undergo sol–gel phase transition were used to develop modulated insulin delivery systems. Glucose-sensitive hydrogels were prepared by mixing glucose-containing polymers and PEGylated concanavalin A (Con A). Glucose was incorporated into the polymer backbone by copolymerization of allyl glucose with comonomers, such as 3-sulfopropylacrylate, potassium salt (SPAK), *N*-vinyl pyrrolidone (VP), and acrylamide (AM). Con A grafted with five PEG molecules were used to improve the stability of Con A. Three different types of insulin delivery systems were examined: diffusion-controlled reservoir, diffusion-controlled matrix, and erosion-controlled matrix systems. Insulin release through the glucose-sensitive hydrogel membrane and from the glucose-sensitive hydrogel matrix was dependent on the glucose concentration in the receptor chamber. As the glucose concentration was increased from 1 to 4 mg/ml, the release rate increased. The insulin release rate decreased as the glucose concentration was reduced to 1 mg/ml. Modulated insulin release was achieved using the glucose-sensitive membrane and matrix systems. On the other hand, the glucose-sensitive erodible system did not show modulated release as the glucose concentration was changed between 1 and 4 mg/ml. © 2001 Elsevier Science B.V. All rights reserved.

Keywords: Modulated insulin delivery; Glucose-sensitive hydrogels; Concanavalin A; PEG; PEGylation; Glucose-containing polymers

1. Introduction

For tight control of hyperglycemia and prevention of the resulting complications in diabetic patients, it is highly desirable to develop a simple, continuous, and non-invasive glucose sensor and an insulin delivery system mimicking physiological insulin release. Of the various delivery techniques that have been developed for insulin delivery [1–13], self-

regulated insulin delivery systems have attracted growing interest due to the presence of both glucose sensing and insulin delivery functions. Our long-term goal is to prepare and characterize self-regulating insulin delivery systems which can detect an increase in the free glucose concentration and deliver an appropriate amount of insulin at an appropriate rate corresponding to the environmental glucose concentration. The gel–sol phase transition behavior of glucose-sensitive hydrogels composed of Con A and glucose-containing polymers have been described previously [14–16]. The gel–sol phase transition in response to the environmental glucose concentration

*Corresponding author. Tel.: +1-765-494-7759; fax: +1-765-496-1903.

E-mail address: kpark@purdue.edu (K. Park).

was reproducible, and the system showed a potential for self-regulated insulin delivery. Our recent study showed that the aqueous solubility and stability of Con A was improved after modification with poly(ethylene glycol) (PEG) [17]. This PEG–Con A conjugate resulted in more reproducible sol–gel phase transitions. In the current study, modulated insulin delivery was examined in more detail using three different types of insulin delivery systems, namely diffusion-controlled membrane and matrix systems, and an erodible matrix system. The diffusion-controlled membrane and matrix systems were constructed with dialysis membranes to retain the hydrogel components inside the systems. For this approach to be successful, the hydrogel components should be retained throughout the experiments and the conditions for phase transition must be also maintained. The erodible matrix system was designed to test the controlled erosion of the hydrogels in response to changes in the environmental glucose concentration.

2. Materials and methods

2.1. Materials

Fluorescence-labeled insulin (FITC-insulin) and concanavalin A (Con A) were purchased from Sigma Chemical Co. (St. Louis, MO) and used without further purification. All other chemicals were of reagent grade. Spectra/Por[®] dialysis membrane (MWCO=50 000) and polyethersulfone membrane (0.1 μm in pore size) were used to support the hydrogels. All aqueous solutions were made using deionized distilled water (DDW). Solutions of Con A conjugates and the copolymers were made in 0.1 M Tris buffer solution (pH 7.4) containing 0.1 M of NaCl, 1 mM of CaCl_2 and MnCl_2 .

2.2. Preparation of PEGylated Con A and glucose-containing polymers

PEGylated Con A was prepared using monomethoxy poly(ethylene glycol)-*p*-nitrophenol carbonate (MPEG–NPC, MW 5000), obtained from Shearwater Polymers (Huntsville, AL), as described previously [17]. Briefly, MPEG–NPC was slowly added to a Con A solution (1 w/v%) in pH 8.5

buffer, and the reaction continued for 20 h. The concentration of MPEG–NPC was varied to control the number of PEG chains grafted on each Con A molecule. In this study, Con A grafted with five MPEG molecules (MPEG5–Con A) were used [17,18].

Synthetic polymers containing glucose were prepared as described previously [14–16]. In this study, glucose-containing polymers were synthesized using allyl glucose (AG) and comonomers, such as 3-sulfopropylacrylate, potassium salt (SPAK), *N*-vinyl pyrrolidone (VP), and acrylamide (AM). The copolymers used in the modulated insulin release experiments were poly(allyl glucose-co-3-sulfopropylacrylate) (P(AG-co-SPAK)), poly(allyl glucose-co-*N*-vinyl pyrrolidone) (P(AG-co-VP)), and poly(allyl glucose-co-acrylamide) (P(AG-co-AM)). The compositions of the glucose-containing polymers were determined by elemental analysis and phenol-sulfuric acid analysis [19]. Molecular weights of glucose-containing polymers were determined by gel permeation chromatography [18], eluting samples from a Ultrahydrogel[®] 500 column (pore size of 500 Å) packed with hydroxylated polymethacrylate-based gel. Eluents were 0.2 M ammonium acetate solution and 0.1 M acetate buffer solution (pH 3.5) for P(AG-co-VP) and P(AG-co-AM) and for P(AG-co-SPAK), respectively.

2.3. Insulin diffusion experiments through glucose-sensitive hydrogel membranes

The Franz diffusion cell was used to investigate diffusion of insulin through the phase-reversible glucose-sensitive hydrogels as a function of glucose concentration. The Franz diffusion cell (PermeGear, Inc., Riegelsville, PA) consists of two compartments, as shown in Fig. 1. The donor compartment was filled with 0.3 ml of insulin solution and the receptor compartment was filled with glucose solution at the appropriate concentrations in 0.1 M Tris buffer. Since insulin dissolves only very slowly in neutral pH solution, it was first dissolved in an acidic solution. A 2-mg quantity of FITC-insulin was dissolved in 0.3 ml of 0.1 N HCl solution with gentle shaking. Then, 1.7 ml of Tris buffer solution was added slowly to the acidic solution. The pH of the final solution was neutral as measured by a pH strip paper. The concentration of insulin was 1 mg/ml and

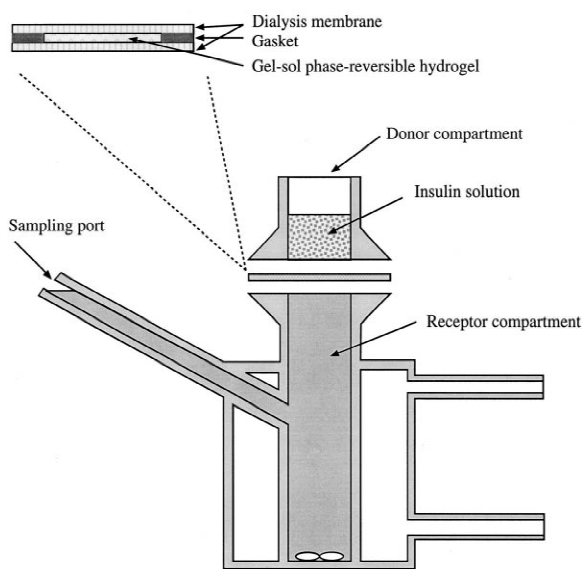

Fig. 1. Schematic description of the Franz diffusion cell used to study diffusion of insulin through a phase-reversible glucose-sensitive hydrogel membrane.

was used in diffusion experiments without dilution. Phase-reversible glucose-sensitive hydrogels were sandwiched between dialysis membranes (MWCO= 50 000) and the thickness of the hydrogels was controlled using a rubber gasket of 0.65 mm (Fig. 2A). The total thickness of the hydrogel layer with

dialysis membranes was 0.75 mm. The hydrogel composite was loaded between the donor and receptor compartments of the diffusion cell and secured with a clamp. The volume of receptor compartment was 4.7 ml and the active area for diffusion was 0.64 cm². Each receptor compartment was mixed with synchronized magnetic stirrers. The glucose concentration in the receptor chamber was changed between physiological relevant concentrations, 1 and 4 mg/ml, in a stepwise pattern (i.e. 1 mg/ml→4 mg/ml→1 mg/ml) at predetermined time intervals. The insulin solution was also changed with a fresh one whenever the glucose receptor solution was changed, in order to maintain the same insulin concentration in the donor compartment at the start of each pulse. A 1-ml sample of receptor solution was taken at predetermined intervals and the fluorescence of FITC-insulin was measured using a fluorescence spectrophotometer (SLM-Aminco® 8000, Spectronic Instruments, Inc., Rochester, NY) with an excitation wavelength of 490 nm and emission at 520 nm. The volume of the receptor solution was maintained by replacing the sample volume with fresh glucose solution. Sink conditions were maintained in the receptor compartment because of the low amounts of the diffused insulin. The concentration of FITC-insulin was determined using a calibration curve constructed with the fluorescence values of

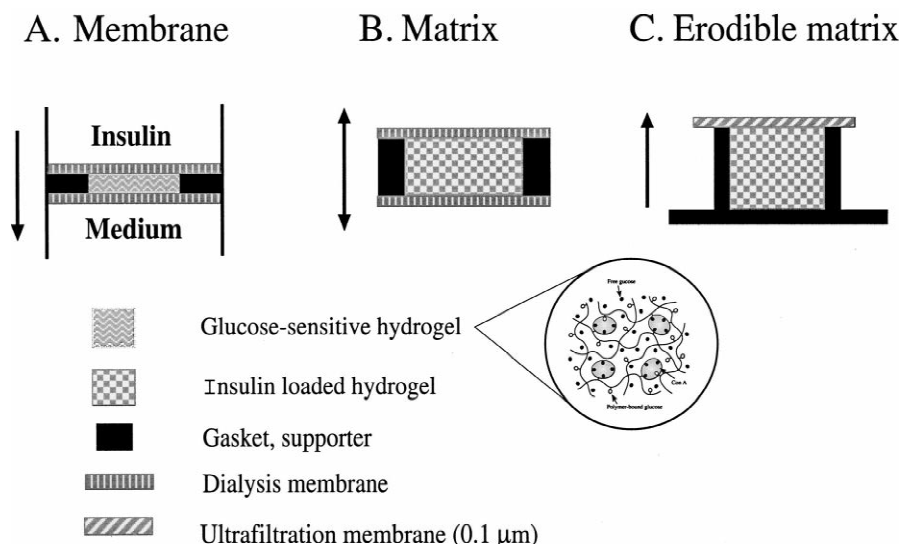

Fig. 2. Three systems for modulated insulin delivery systems using phase-reversible glucose-sensitive hydrogels. Arrows indicate the direction of insulin release from the systems.

known amounts of FITC-insulin. All experiments were performed at room temperature.

2.4. Insulin release through glucose-sensitive hydrogel matrices

The glucose-sensitive hydrogel matrices were prepared by loading FITC-insulin into the phase-reversible glucose-sensitive hydrogels at a concentration of 0.7 mg/ml, and the matrices were sandwiched between dialysis membranes (MWCO=50 000) as shown in Fig. 2B. To control the thickness of matrices with attached dialysis membranes, a disk was cut from a poly(methyl methacrylate) plate. The membrane was placed over the hole on one side of the plate, and bonded using an instant cyanoacrylate adhesive. Special care was made not to block the active area of membrane with the adhesive. The matrix components were loaded into the hole and the other side of the hole was sealed with the second dialysis membrane. The thickness of the hydrogel matrix was 0.31 cm and volume was 0.38 cm³. The active surface area for insulin diffusion was 2.45 cm². To prepare a glucose-sensitive hydrogel, MPEG5-Con A was used at a concentration of 140 mg/ml. The concentrations of P(AG-co-AM), P(AG-co-VP), and P(AG-co-SPAK) were 20, 20, and 30 mg/ml, respectively. The matrices were placed in 50 ml glucose solutions. The solutions were stirred with magnetic stirrers. A 1-ml sample of solution was taken at predetermined time intervals and the same amount of fresh glucose solution was added to the medium to maintain the volume constant. The glucose solutions were changed in a stepwise pattern (1 mg/ml→4 mg/ml→1 mg/ml) at predetermined time intervals. The experiments were performed for 60 h. All experiments were performed at room temperature.

2.5. Insulin release experiments using erodible glucose-sensitive hydrogel matrices

Insulin release experiments were performed using glucose-sensitive hydrogel matrices that were eroded as a function of glucose concentration and time. The matrices were prepared using phase-reversible glucose-sensitive hydrogels and insulin. An insulin solution, 1.0 mg/ml, was mixed with the hydrogels and placed in small glass cylinder that had only one

end open. The open end of the glass was sealed with ultrafiltration membrane filter (0.1 μm in pore size) as shown in Fig. 2C. Ultrafiltration membranes were used as a minimal barrier to convection flow of the medium. It was assumed that the gel components would be highly permeable at a sol state. The active surface area of the membrane was 2.4 cm², and the thickness of the hydrogel matrix was 0.5 cm. The glass device containing the hydrogel was placed at the bottom of beaker and an impeller of a mechanical agitator was set 2.5 cm above the device. The volume of the release medium was 300 ml and the medium was stirred at 50 rpm. The release medium was glucose solutions in 0.1 M Tris buffer, pH 7.4. The glucose concentration was changed between 1 and 4 mg/ml in a stepwise pattern (1 mg/ml→4 mg/ml→1 mg/ml) every 5 h for 20 h. A 1-ml sample of solution was taken at predetermined time intervals and the same amount of fresh glucose solution was added to the medium to maintain the volume constant. MPEG5-Con A was used at a concentration of 140 mg/ml, and the concentrations of P(AG-co-AM) and P(AG-co-VP2) in the matrices were each 20 mg/ml. The amount of released insulin was determined by measuring fluorescence of FITC-insulin. All experiments were performed at room temperature.

3. Results

3.1. Glucose-containing polymers

Glucose-containing copolymers were prepared by free radical polymerization using AM, VP, and SPAK as comonomers. More than ten different copolymers with different AG mol fractions were prepared and tested for their ability to form hydrogels in the presence of MPEG5-Con A. Based on a preliminary study, three copolymers were chosen, and their glucose contents as measured by elemental analysis and phenol-sulfuric acid assay are listed in Table 1. The mol fraction of AG in copolymers was usually less than that in the feed solutions. Most of AG was incorporated into copolymers with VP, but the AG incorporation was less when the comonomers were either AM or SPAK. For P(AG-co-SPAK), less than 50% of the AG in the feed solution was incorporated into the copolymer. To prepare the copolymers with an AG mol fraction of at least 0.1, the mol fractions

Table 1
Mole fractions of AG in the copolymers

	Mole fraction of AG in feed	Mole fraction of AG in copolymer
P(AG-co-AM)	0.17	0.12
P(AG-co-VP)	0.14	0.13
P(AG-co-SPAK)	0.39	0.17

of AG in the feed solutions were adjusted depending on the type of comonomer used. The data on molecular weights and polydispersity of glucose-containing polymers are summarized in Table 2. The molecular weights of P(AG-co-AM) and P(AG-co-VP) were much higher than those of P(AG-co-SPAK). The polydispersity of copolymers was about 3, indicating a rather wide distribution in molecular weights. The low molecular weight and high polydispersity of copolymers were most likely due to the low reactivity ratio of AG monomer.

3.2. Insulin release through glucose-sensitive hydrogel membranes

Fig. 3 shows the cumulative amount of insulin released through a glucose-sensitive hydrogel membrane in response to stepwise changes of the glucose concentration. To examine changes of the insulin release rate as a function of the glucose concentration, the release rates were calculated as shown at the bottom of Fig. 3. Pulsatile insulin release patterns were observed as the glucose concentration changed. As the glucose concentration of receptor compartment increased from 1 to 4 mg/ml, the insulin release rate increased four-fold from 0.1 to 0.4 $\mu\text{g}/\text{cm}^2/\text{h}$. It took about 90 min to reach the release rate of 0.3 $\mu\text{g}/\text{cm}^2/\text{h}$, and the rate continued to increase slowly for the remaining 3.5 h. When the glucose concentration of the release medium was lowered to 1 mg/ml at $t=10$ h, the release rate decreased sharply. It took only about 30 min to reach the

Table 2
Molecular weights and polydispersity of glucose-containing polymers

	M_n	M_w	M_w/M_n
P(AG-co-AM)	29,200	78,500	2.69
P(AG-co-VP)	47,600	145,200	3.05
P(AG-co-SPAK)	16,200	42,930	2.65

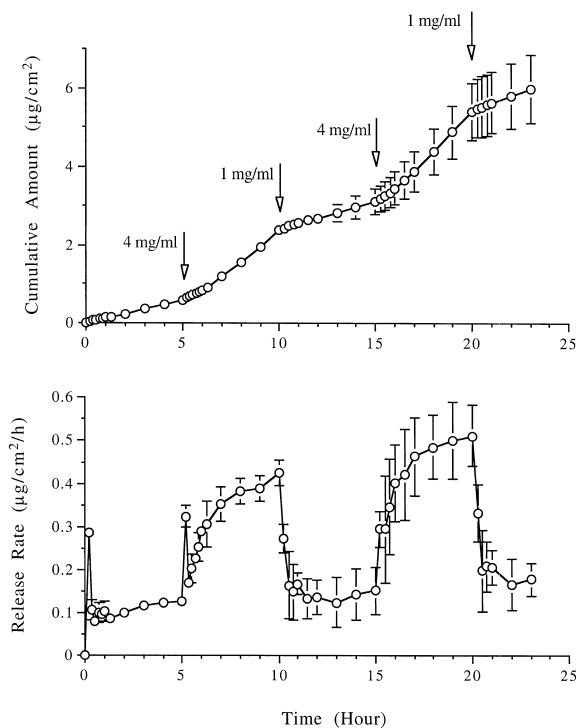

Fig. 3. Cumulative amount of the released insulin and insulin release rate as a function of time through glucose-sensitive hydrogel membranes under stepwise changes of the glucose concentration. The hydrogel was composed of PEGylated Con A (14 w/v%) and P(AG-co-SPAK) (3 w/v%). The glucose concentration at the receptor chamber was changed to either 1 mg/ml or 4 mg/ml at the times indicated by arrows ($n=4$).

release rate of 0.16 $\mu\text{g}/\text{cm}^2/\text{h}$. Changes in the insulin release rate were highly dependent on the glucose concentration in the medium. Even though glucose diffused through the hydrogel membrane to the upper donor compartment, changes in the glucose concentration in the receptor compartment was thought to be negligible due to the small volume of donor compartment. Whenever the whole medium in the receptor compartment was changed, the donor compartment was also replenished with a new insulin solution. This provided the a relatively constant insulin concentration and minimal glucose content in the donor compartment.

To calculate the lag time to reach steady-state release with a change of glucose concentration in the receptor, the released insulin was measured as a function of time after the glucose concentration was changed from 1 to 4 mg/ml in the beginning of the

experiment (Fig. 4). The system worked as a diffusion-controlled reservoir system. Since glucose is much smaller than insulin, it quickly diffused into the hydrogel membrane from the receptor chamber. As the glucose concentration increased within the hydrogel membrane, the hydrogel was transformed into a sol state, leading to increased diffusion of insulin within the membrane. Thus, the lag time here includes time for glucose diffusion from the receptor chamber to the donor chamber. Separating this component from the overall lag time has inherent inaccuracy, since insulin could still diffuse through the hydrogel, although much slower than through the sol [16]. The lag time (t_L) calculated from the data in Fig. 4 was 0.5 h. Since t_L is equal to $h^2/6D$, where h is the membrane thickness, the diffusion coefficient of insulin, D , can be calculated. In this study, the thickness of the hydrogel membrane was 650 μm and each of dialysis membranes was 50 μm . Thus, the total thickness of the membrane composite was 750 μm , and this leads to the calculated diffusion coefficient of $5.2 \times 10^{-7} \text{ cm}^2/\text{s}$. The diffusion coefficient of insulin in water at 20°C is in the range of 7.5×10^{-7} – $16 \times 10^{-7} \text{ cm}^2/\text{s}$ [20]. The diffusion coefficient of insulin obtained from this study is at the lower end of the known values. This can be explained because the membrane in the sol state has dissolved polymer molecules that increase the medium viscosity. The calculated value, however, is still greater than the values obtained through the highly swollen hydrogel membranes, which were in the range of 1.0×10^{-7} – $4.8 \times 10^{-7} \text{ cm}^2/\text{s}$ [21].

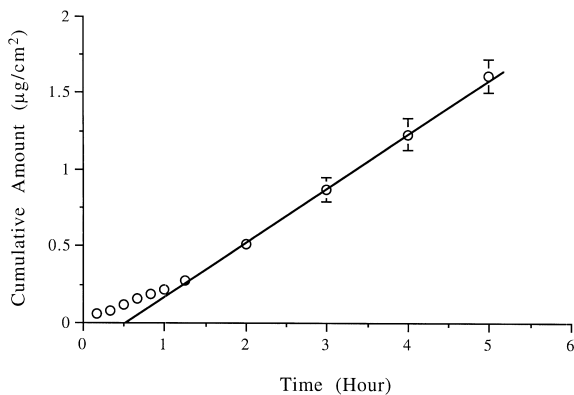

Fig. 4. Cumulative amount of the released insulin as a function of time through glucose-sensitive P(AG-co-SPAK) hydrogel membranes. The glucose concentration at the receptor chamber was changed to 4 mg/ml at $t=0$ ($n=4$).

Thus, it appears that at the glucose concentration of 4 mg/ml the hydrogel membrane in the sol state provides a medium for insulin diffusion similar to water.

Insulin release experiments using P(AG-co-VP)/MPEG5–Con A hydrogel membranes were also performed for more than 80 h. Fig. 5 shows a release profile of insulin through a glucose-sensitive hydrogel. A pulsatile release pattern of insulin was observed in response to changes of the glucose concentration. The insulin release rate was lower than that through the hydrogel composed of P(AG-co-SPAK) and MPEG5–Con A. The insulin release rates in both P(AG-co-SPAK) and P(AG-co-VP) hydrogels seem to be correlated with the results of viscosity changes of the hydrogels in response to changes in the glucose concentration [18]. A higher viscosity of the hydrogel resulted in a lower release rate of insulin. For both hydrogels, the insulin release rate increased as the phase transition was repeated.

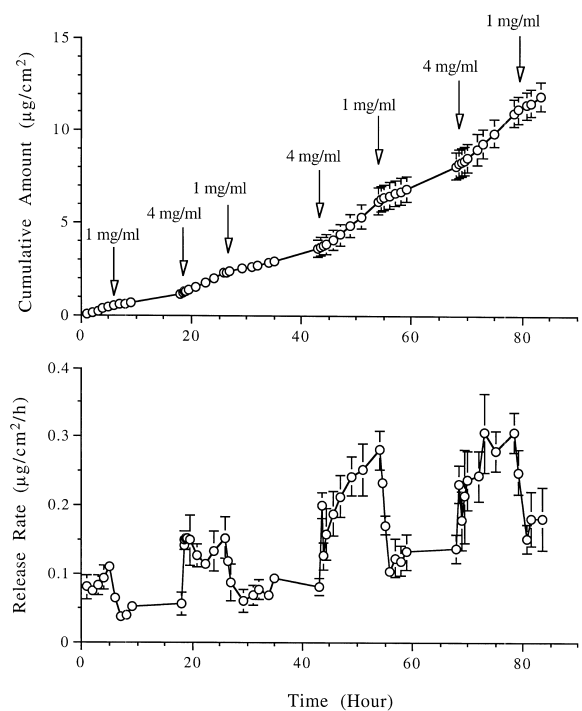

Fig. 5. Cumulative amount of the released insulin and insulin release rate as a function of time through glucose-sensitive hydrogel membranes under stepwise changes of the glucose concentration. The hydrogel was composed of PEGylated Con A (14 w/v%) and P(AG-co-VP) (2 w/v%). The glucose concentration at the receptor chamber was changed to either 1 mg/ml or 4 mg/ml at the times indicated by arrows ($n=4$).

For P(AG-co-VP) hydrogel membranes, the insulin release rate increased by twofold after 50 h in comparison with that of the earlier time period. In addition, the release rate at the glucose concentration of 1 mg/ml also increased. Figs. 3 and 5 both showed a time-dependent increase in the release rate.

3.3. Insulin release from glucose-sensitive hydrogel matrices

Fig. 6 shows release profiles of insulin from the glucose-sensitive hydrogel matrices. The insulin release rates from three different hydrogel matrices were similar. As in the case of the hydrogel membranes, hydrogel matrices also showed pulsatile release of insulin as the glucose concentration was changed between 1 and 4 mg/ml. There are, however, a few differences in the insulin release pattern

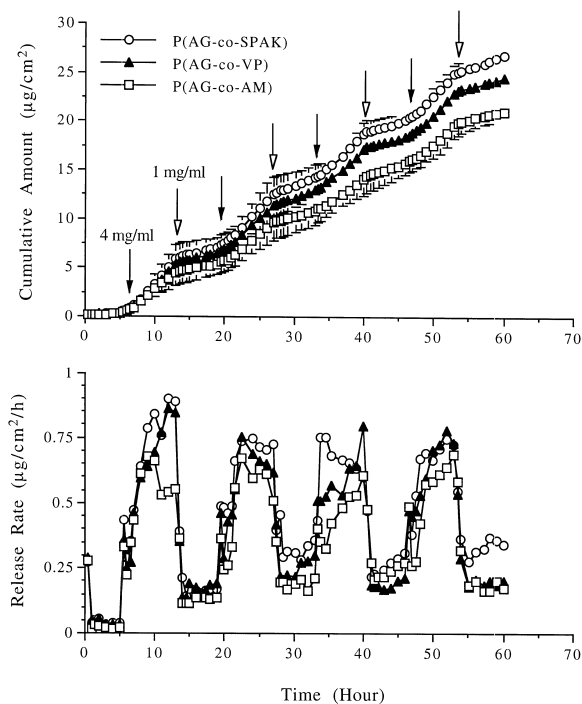

Fig. 6. Cumulative amount of the released insulin and insulin release rate as a function of time through glucose-sensitive hydrogel matrices under stepwise changes of the glucose concentration. The hydrogel were made from PEGylated Con A (14 w/v%) and different copolymers: P(AG-co-SPAK) (3 w/v%); P(AG-co-VP) (2 w/v%); and P(AG-co-AM) (2 w/v%). The glucose concentration at the receptor chamber was changed to either 1 mg/ml (open arrows) or 4 mg/ml (closed arrows). For simplicity, the error bars in the release rates are not shown ($n=3$).

between the membrane and the matrix systems. First, in the matrix system, the base line insulin release rate when the glucose concentration was 1 mg/ml did not increase as much as in the membrane system (as shown in Fig. 5). Second, the insulin release rates at the glucose concentration of 4 mg/ml decreased a small amount in the matrix system as the phase transition was repeated. This is a noticeable difference from the increasing release rates observed with the membrane system (in Fig. 5).

3.4. Insulin release from erodible glucose-sensitive hydrogel matrices

Fig. 7 shows release profiles of insulin from the erodible hydrogel matrices made of P(AG-co-AM) and P(AG-co-VP). When the glucose concentration was changed to 4 mg/ml at $t=5.25$ h, an immediate increase in insulin release rate was observed. The increased release rate was maintained for about 2 h and then decreased even without changing the glucose concentration back to 1 mg/ml. As shown by

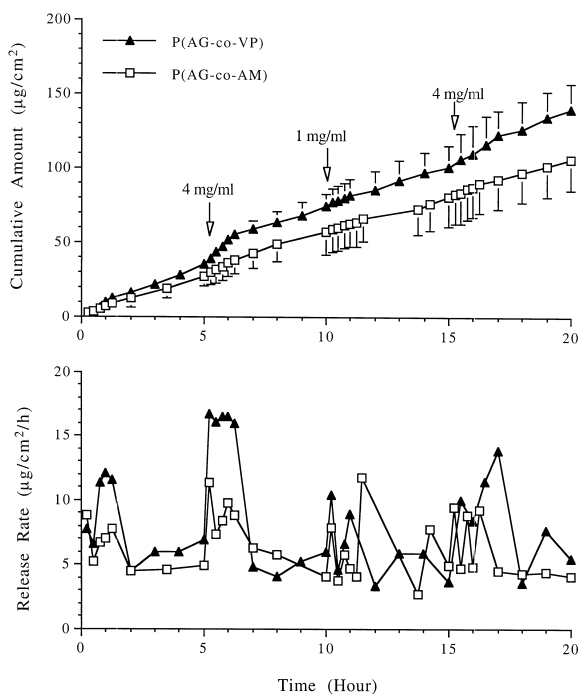

Fig. 7. Cumulative amount of the insulin released from erodible glucose-sensitive hydrogel matrices as a function of time. The hydrogels were prepared using PEGylated Con A (14 w/v%) and P(AG-co-AM) (2 w/v%) or P(AG-co-VP) (2 w/v%) ($n=3$).

the release rate at the bottom of Fig. 7, no clear correlation of increased release rate and increased glucose concentration was observed. Simply put, modulated insulin release was not observed using erodible matrices, and the insulin release was independent on the glucose concentration. The data indicate that insulin was freely permeable through the matrix even when the glucose concentration in the bulk solution was changed to 1 mg/ml. It appears that once glucose molecules entered the erodible matrix, they remained inside the matrix even after the glucose concentration in the solution was lowered. Continuous loss of the hydrogel components from the erodible matrix may make it difficult to control the insulin release.

4. Discussion

In this study, three different types of glucose-sensitive hydrogel systems were tested for their ability to modulate insulin release as a function of the glucose concentration in the environment. Studies with glucose-sensitive hydrogel membrane and matrix systems showed that the insulin release could be modulated. On the other hand, it was not possible to control insulin release rate using the erodible hydrogel system. The membrane system showed the overall better performance in modulating insulin release than the matrix system. While the results of modulated insulin release shown by the membrane and matrix systems are encouraging, they also showed that the systems require significant improvements to be useful. One of the urgent improvements to be made is in membranes that can retain the hydrogel components inside and at the same time allow rapid diffusion of insulin molecules.

As the sol–gel phase transition was repeated in the membrane and matrix systems, the release rates at the glucose concentrations of 1 mg/ml as well as at 4 mg/ml gradually increased. Both Figs. 3 and 5 show this trend. Furthermore, the release rate became more variable at later times than at earlier times, i.e. the error bars became larger as the sol–gel phase transition was repeated. These observations can be explained by the loss of the gel components, even though in small quantities, as the phase transition is repeated. In a sol state, a gel component may diffuse out of the membrane as well as insulin. Since

MPEG5–Con A forms a tetramer (molecular weight of 110 000) under the experimental conditions, MPEG5–Con A does not permeate through the dialysis membrane (MWCO=50 000). However, glucose-containing polymers can be lost from the membrane composites, because the molecular weights of the polymers are less than the MWCO of the dialysis membrane. In our previous studies, dialysis membranes with smaller MWCO were used with little success [14]. Insulin could not diffuse through the dialysis membranes most likely due to aggregation. Physical instability and adsorption of insulin on surfaces are the most common problems encountered in dealing with insulin solutions [22–24]. The urea in the 1–3 mg/ml range is known to minimize both insulin self-association and surface adsorption [25]. We noticed, however, that the concentration of insulin we used (1 mg/ml) was too high to prevent self-association with urea [26]. It was necessary to choose the supporting membrane with a pore size large enough for diffusion of insulin, but this caused release of the hydrogel components [15,16]. The problem of the increasing release rate in time may be prevented if suitable membranes are used that prevent any loss of the hydrogel components. Despite the loss of the hydrogel components, the membrane and matrix systems have clearly shown that the insulin release can be modulated by the glucose concentration in the environment. In addition, it was also shown that the insulin diffusion through the sol is several times faster than that through the gel. The insulin release rate can be changed quickly, e.g. in less than 5 min, by reducing the thickness of the membrane or matrix.

While the membrane system appears to be best in terms of modulating insulin release, it may not be as easy to develop as other systems, such as matrix and erodible systems, for clinical applications. The matrix system may be easier to make than the membrane system, but the matrix system must be implanted and then removed after use. The matrix system that can be refillable by injection may be developed, but it may still not be simple enough to be practical. The most useful system for clinical applications appears to be the erodible system. This is especially true if the eroded components are biocompatible and excretable from the body, or biodegradable polymers can be developed in the future. The erodible system, however, did not show

the pulsatile insulin release in response to the changes in the glucose concentration. The main problem seems to be the lack of a mechanism for fast removal of glucose from the system once the environmental glucose concentration decreases.

In summary, this study has shown that the sol–gel phase reversible hydrogels can be used to modulate insulin release in response to changes in physiological glucose concentrations between 1 and 4 mg/ml. The membrane and matrix systems clearly showed the modulated insulin release. Although modulated insulin release from the erodible system was not as efficient as the other two systems, it showed the potential to provide long-term delivery of insulin. With continuous improvements in polymer membranes and biodegradable polymers, we can expect that the systems tested in this study can be further developed for practical applications.

Acknowledgements

This study was supported by the NIH through grant DK54164.

References

- [1] M. Brownlee, A. Cerami, A glucose-controlled insulin-delivery system: semisynthetic insulin bound to lectin, *Science* 206 (1979) 1190–1191.
- [2] G. Albin, T.A. Horbett, B.D. Ratner, Glucose sensitive membranes for controlled delivery of insulin: Insulin transport studies, *J. Controlled Rel.* 2 (1985) 153–164.
- [3] L.A. Seminoff, G.B. Olsen, S.W. Kim, A self-regulating insulin delivery system. I. Characterization of a synthetic glycosylated insulin derivative, *Int. J. Pharm.* 54 (1989) 241–249.
- [4] S.W. Kim, C.M. Pai, K. Makino, L.A. Seminoff, D.L. Holmberg, J.M. Gleeson, D.E. Wilson, E.J. Mack, Self-regulated glycosylated insulin delivery, *J. Control. Release* 11 (1990) 193–201.
- [5] V.V. Ranade, Drug delivery systems. 4. Implants in drug delivery, *J. Clin. Pharmacol.* 30 (1990) 871–889.
- [6] K. Sawahata, M. Hara, H. Yasunaga, Y. Osada, Electrically controlled drug delivery system using polyelectrolyte gels, *J. Control. Release* 14 (1990) 253–262.
- [7] F.P. Kennedy, Recent developments in insulin delivery techniques. Current status and future potential, *Drugs* 42 (1991) 213–227.
- [8] C.D. Saudek, Future developments in insulin delivery systems, *Diabetes Care* 16 (1993) 122–132.
- [9] C. Stewart, N.A. Taylor, I.C. Green, K. Docherty, C.J. Bailey, Insulin-releasing pituitary cells as a model for somatic cell gene therapy in diabetes mellitus, *J. Endocrinol.* 142 (1994) 339–343.
- [10] M.J. Taylor, S. Tanna, P.M. Taylor, G. Adams, Delivery of insulin from aqueous and nonaqueous reservoirs governed by a glucose sensitive gel membrane, *J. Drug Target.* 3 (1995) 209–216.
- [11] L.R. Brown, E.R. Edelman, F. Fischel-Ghodsian, R. Langer, Characterization of glucose-mediated insulin release from implantable polymers, *J. Pharm. Sci.* 85 (1996) 1341–1345.
- [12] K. Iwanaga, S. Ono, K. Narioka, K. Morimoto, M. Kakemi, S. Yamashita, M. Nango, N. Oku, Oral delivery of insulin by using surface coating liposomes improvement of stability of insulin in GI tract, *Int. J. Pharm.* 157 (1997) 73–80.
- [13] J.L. Selam, Management of diabetes with glucose sensors and implantable insulin pumps. From the dream of the 60s to the realities of the 90s, *ASAIO J.* 43 (1997) 137–142.
- [14] S.J. Lee, K. Park, Synthesis and characterization of sol–gel phase-reversible hydrogels sensitive to glucose, *J. Mol. Recogn.* 9 (1996) 549–557.
- [15] A.A. Obaidat, K. Park, Characterization of glucose dependent gel–sol phase transition of the polymeric glucose–concanavalin A hydrogel system, *Pharm. Res.* 13 (1996) 989–995.
- [16] A.A. Obaidat, K. Park, Characterization of protein release through glucose-sensitive hydrogel membranes, *Biomaterials* 18 (1997) 801–806.
- [17] J.J. Kim, K. Park, K., Glucose-binding property of PEGylated concanavalin A, *Pharm. Res.* (2001) in press.
- [18] J.J. Kim, Phase-reversible glucose-sensitive hydrogels for modulated insulin delivery, PhD thesis, Purdue University, West Lafayette, IN, 1999.
- [19] M. Dubois, K.A. Gilles, J.K. Hamilton, P.A. Rebers, F. Smith, Colorimetric method for determination of sugars and related substances, *Anal. Chem.* 28 (1956) 350–356.
- [20] M.H. Smith, Molecular weights of proteins and some other materials including sedimentation, diffusion and frictional coefficients and partial specific volumes, in: H.A. Sober (Ed.), *Handbook of Biochemistry*, 2nd Edition, CRC Press, Cleveland, OH, 1970, pp. C3–C35.
- [21] M.V. Sefton, E. Nishimura, Insulin permeability of hydrophilic polyacrylate membranes, *J. Pharm. Sci.* 69 (1980) 208–209.
- [22] M. Baudys, T. Uchio, D. Mix, D. Wilson, S.W. Kim, Physical stabilization of insulin by glycosylation, *J. Pharm. Sci.* 84 (1995) 28–33.
- [23] A. Oliva, J. Farina, M. Llabres, Analysis of peptides and proteins: evaluation of purity, stability, and structural characterization of insulin, *Drug Dev. Ind. Pharm.* 23 (1997) 915–927.
- [24] V. Sluzky, J.A. Tamada, A.M. Klibanov, R. Langer, Kinetics of insulin aggregation in aqueous solutions upon agitation in the presence of hydrophobic surfaces, *Proc. Natl. Acad. Sci. USA* 88 (1991) 9377–9381.
- [25] S. Sato, C.D. Ebert, S.W. Kim, Prevention of insulin self-association and surface adsorption, *J. Pharm. Sci.* 72 (1983) 228–232.
- [26] Y.W. Chien, Human insulin: Basic sciences to therapeutic uses, *Drug Dev. Ind. Pharm.* 22 (1996) 753–789.